



Soft Jaw For Hydraulic Power Chucks



For Japanese brand JIS & KITAGAWA

STANDARD
3 PCS/SET

ALUMINIUM

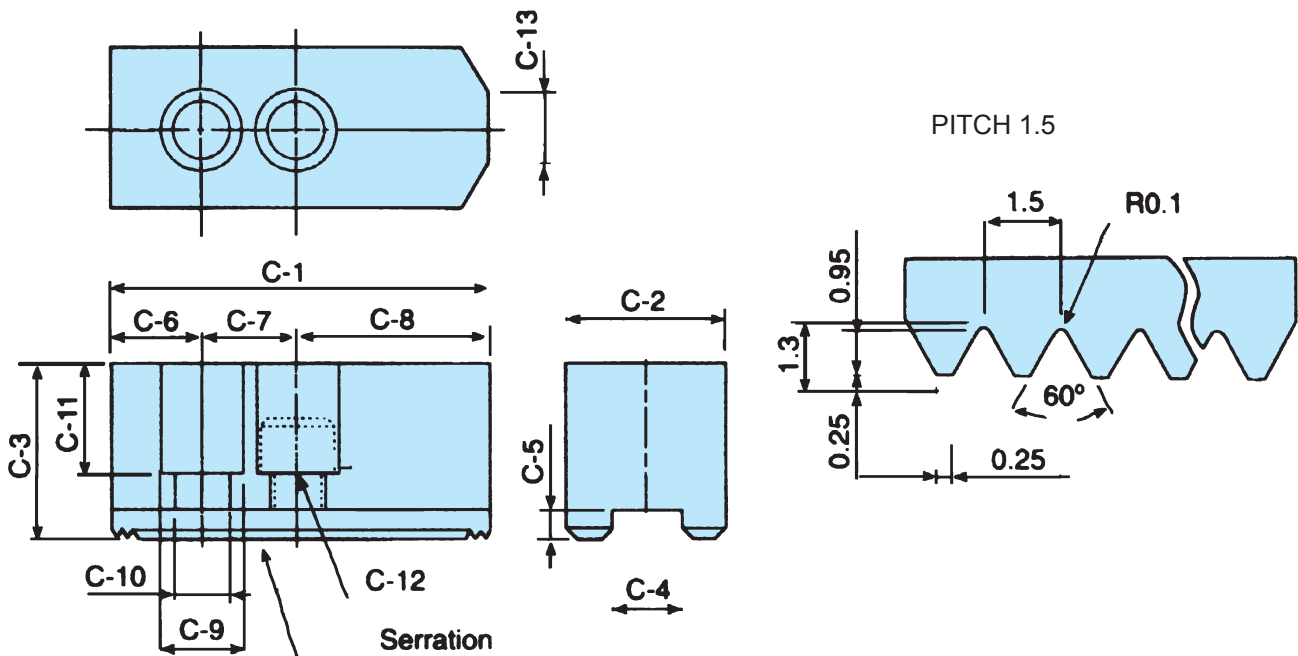
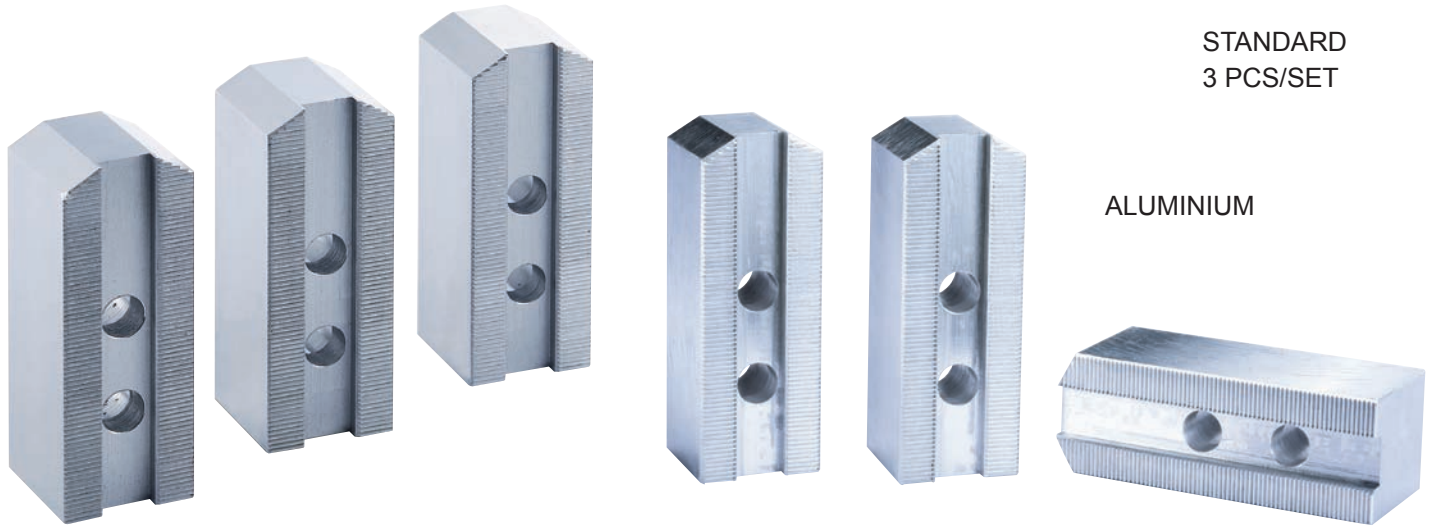

MATERIAL: STEEL

Unit:mm

Dim	C-1	C-2	C-3	C-4	C-5	C-6	C-7	C-8	C-9	C-10	C-11	C-12	C-13	Weight (kgs)	CODE NO.
VHC-05	62	25	30	10	5	9	14	39	13.5	9	21	M8	5	0.9	5002-330
VHC-06	73	31	36	12	5	15	20	38	17	11	23	M10	14	1.6	5002-331
VHC-08	95	35	37	14	5	24	25	46	19	13	22	M12	16	2.4	5002-332
VHC-10	110	40	42	16	5	30	30	50	19	13	27	M12	18	3.7	5002-333
VHC-12	130	50	50	21	5	39	30	61	25	17	30	M16	23	6.4	5002-334
VHC-15	165	62	62	22	8	37	43	85	32	21	38	M20	-	12.7	5002-335
VHC-12-1	130	50	50	18	5	39	30	61	23	15	30	M14	23	6.25	5002-336
VHC-15-1	165	62	62	25.5	5	37	43	85	32	21	38	M20	-	13	5002-337
VHC-24	180	64	70	25	9	40	60	80	32	21	45	M20	-	17	5002-338

MATERIAL : ALUMINIUM

Unit:mm

Dim	C-1	C-2	C-3	C-4	C-5	C-6	C-7	C-8	C-9	C-10	C-11	C-12	C-13	Weight (kgs)	CODE NO.
VHC-8A	95	35	37	14	5	24	25	46	19	13	22	M12	16	0.84	5002-250A
VHC-10A	110	40	42	16	5	30	30	50	19	13	27	M12	18	1.31	5002-251A



THE SPECIAL OF HEIGHT (C-3) FOR VHC-TYPE IS AVAILABLE

ORDER NO.	MODEL	HEIGHT	CODE NO.
VHC-05-5	VHC-05	50H	5002-3305
VHC-05-6	VHC-05	60H	5002-3306
VHC-05-7	VHC-05	70H	5002-3307
VHC-05-8	VHC-05	80H	5002-3308
VHC-06-5	VHC-06	50H	5002-3315
VHC-06-6	VHC-06	60H	5002-3316
VHC-06-7	VHC-06	70H	5002-3317
VHC-06-8	VHC-06	80H	5002-3318
VHC-06-9	VHC-06	90H	5002-3319
VHC-06-10	VHC-06	100H	5002-3320
VHC-06-11	VHC-06	110H	5002-3321
VHC-06-12	VHC-06	120H	5002-3322
VHC-06-13	VHC-06	130H	5002-3323
VHC-06-15	VHC-06	150H	5002-3324
VHC-08-5	VHC-08	50H	5002-3325
VHC-08-6	VHC-08	60H	5002-3326
VHC-08-7	VHC-08	70H	5002-3327
VHC-08-8	VHC-08	80H	5002-3328
VHC-08-9	VHC-08	90H	5002-3329
VHC-08-10	VHC-08	100H	5002-3330
VHC-08-11	VHC-08	110H	5002-3331
VHC-08-12	VHC-08	120H	5002-3332
VHC-08-13	VHC-08	130H	5002-3333
VHC-08-14	VHC-08	140H	5002-3334
VHC-08-15	VHC-08	150H	5002-3334A
VHC-08-16	VHC-08	160H	5002-3334B
VHC-08-18	VHC-08	180H	5002-3334C
VHC-08-20	VHC-08	200H	5002-3334D
VHC-10-5	VHC-10	50H	5002-3335
VHC-10-6	VHC-10	60H	5002-3336
VHC-10-7	VHC-10	70H	5002-3337
VHC-10-8	VHC-10	80H	5002-3338
VHC-10-9	VHC-10	90H	5002-3339
VHC-10-10	VHC-10	100H	5002-33310
VHC-10-11	VHC-10	110H	5002-33311

ORDER NO.	MODEL	HEIGHT	CODE NO.
VHC-10-12	VHC-10	120H	5002-33312
VHC-10-13	VHC-10	130H	5002-33313
VHC-10-14	VHC-10	140H	5002-33314
VHC-10-15	VHC-10	150H	5002-33315
VHC-10-16	VHC-10	160H	5002-33316
VHC-10-18	VHC-10	180H	5002-33318
VHC-10-20	VHC-10	200H	5002-33320
VHC-10-22	VHC-10	220H	5002-33322
VHC-12-6A	VHC-12 18SLOT	60H	5002-3366
VHC-12-7A	VHC-12 18SLOT	70H	5002-3367
VHC-12-8A	VHC-12 18SLOT	80H	5002-3368
VHC-12-9A	VHC-12 18SLOT	90H	5002-3369
VHC-12-10A	VHC-12 18SLOT	100H	5002-33610
VHC-12-6	VHC-12 21SLOT	60H	5002-3346
VHC-12-8	VHC-12 21SLOT	80H	5002-3348
VHC-12-10	VHC-12 21SLOT	100H	5002-33410
VHC-12-11	VHC-12 21SLOT	110H	5002-33411
VHC-12-12	VHC-12 21SLOT	120H	5002-33412
VHC-12-13	VHC-12 21SLOT	130H	5002-33413
VHC-12-14	VHC-12 21SLOT	140H	5002-33414
VHC-12-15	VHC-12 21SLOT	150H	5002-33415
VHC-12-16	VHC-12 21SLOT	160H	5002-33416
VHC-12-17	VHC-12 21SLOT	170H	5002-33417
VHC-12-18	VHC-12 21SLOT	180H	5002-33418
VHC-12-19	VHC-12 21SLOT	190H	5002-33419
VHC-12-20	VHC-12 21SLOT	200H	5002-33420
VHC-15-7	VHC-15	70H	5002-3357
VHC-15-8	VHC-15	80H	5002-3358
VHC-15-9	VHC-15	90H	5002-3359
VHC-15-10	VHC-15	100H	5002-33510
VHC-15-12	VHC-15	120H	5002-33512
VHC-15-15	VHC-15	150H	5002-33515
VHC-15-18	VHC-15	180H	5002-33518
VHC-15-20	VHC-15	200H	5002-33520