

# Ground Parallels



ORDER NO.VP-100 CODE NO.1004-001

To provide more convenient processing for milling vise.



- Hardness: HRC 48°-53°
- Accuracy: 0.01mm
- Process: Four-side ground
- 1 set includes 18 pcs
- Packed by plastic case, G.W: 11.7 kgs, Meas: 0.3 CFT
- Dimension: 390x292x84mm



Unit: mm

BODY SIZE	CLAMP SIZE
WxHxLxPcs	AxBxCxLxPcs
5x16x100x2	15x31x2 5x200x2
6x18x100x2	
8x24x100x2	
10x30x100x2	
12x36x150x2	
14x48x150x2	
18x60x150x2	
22x62x150x2	

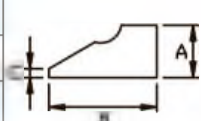

# Ground Parallels

ORDER NO.VP-118A CODE NO.1004-010

8.5mm WIDTH, 5.8kgs



- Hardness: HRC 48°-53°
- MADE OF HIGH GRADE ALLOY STEEL HARDENED AND GROUND
- Dimension: 290x228x80mm

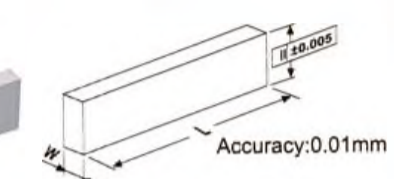

Unit: mm

WxHxLxPcs	
8.5x14x150x2	8.5x32x150x2
8.5x16x150x2	8.5x36x150x2
8.5x20x150x2	8.5x40x150x2
8.5x24x150x2	8.5x44x150x2
8.5x30x150x2	

# Ground Parallels

ORDER NO.VP-128A CODE NO.1004-020

28 PCS/SET 10.7kgs

VP-128A 10mm WIDTH



- Hardness: HRC 48°-53°
- MADE OF HIGH GRADE ALLOY STEEL HARDENED AND GROUND.
- Dimension: 390x292x82mm



WxHxLxPcs	
10x14x150x2	10x28x150x2
10x16x150x2	10x30x150x2
10x18x150x2	10x32x150x2
10x20x150x2	10x35x150x2
10x22x150x2	10x40x150x2
10x24x150x2	10x45x150x2
10x26x150x2	10x50x150x2

Unit: mm

# VP-146 Ground Parallels

ORDER NO.VP-146 CODE NO:1004-082

4.6Wx150Lx12 PCS/SET

Accuracy: 0.01 mm

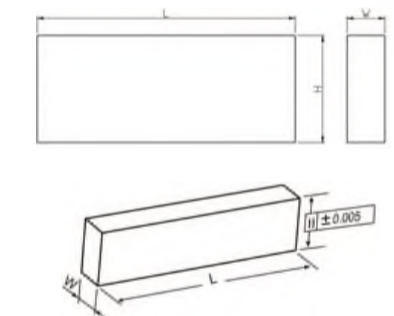

- G.W. 3kgs.
- Material: S45C
- Hardness: HRC48°-53°

WxHxLxPCS
4.6x32x150x2
4.6x34x150x2
4.6x36x150x2
4.6x38x150x2
4.6x40x150x2
4.6x44x150x2

- Dimension: 195x180x90mm

# VP-168 Ground Parallels

ORDER NO.VP-168 CODE NO:1004-083

6.8Wx150Lx14 PCS/SET

Accuracy: 0.01 mm

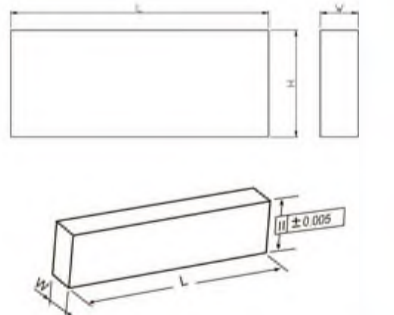

- G.W. 3.5kgs
- Material: S45C
- Hardness: HRC48°-53°

WxHxLxPCS
6.8x15x150x2
6.8x18x150x2
6.8x21x150x2
6.8x25x150x2
6.8x27x150x2
6.8x31x150x2
6.8x35x150x2

- Dimension: 225x200x90mm

# VP-200 Ground Parallels

ORDER NO.VP-200 CODE NO.1004-085



- MADE OF HIGH GRADE ALLOY STEEL HARDENED AND GROUND.
- ACCURACY: 0.01/100 MM
- G.W. :15.6 KGS



FOR OVER 150 mm, 200mm JAW PLATE VISE USING

- Dimension: 355x318x85mm

BODY SIZE	CLAMP SIZE
AxBxLxPcs	AxBxCxLxPcs
5x16x150x2	31x15x200x2x2.5
6x18x150x2	
8x24x150x2	
10x30x150x2	
12x36x200x2	
14x48x200x2	
18x60x200x2	
22x62x200x2	

