

Precision Universal Angle Chuck

With VSC-4 Chuck

NEW

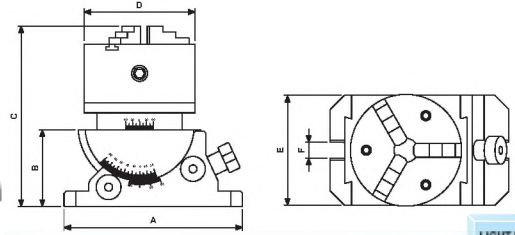

- With VSC-4 3-Jaw chuck.
- O.D. clamping Ø3-90 mm.
- I.D. clamping Ø32-84 mm.
- Tolerance ±0.01mm/100mm.
- 2 axis with angle scale
- For angle setting
- Chuck indexing / Rotating setting by scale.
- Tilting Features same as VUA series, Page B13.
- Load Capacity :25Kgs



ORDER NO.	A	B	C	D	E	F	G.W (kgs)	CODE NO.
VUA-100J	180	77	181	112	110	16	14	2003-060

Precision Universal Angle Collet Chuck

Capacity Ø3-Ø30

NEW

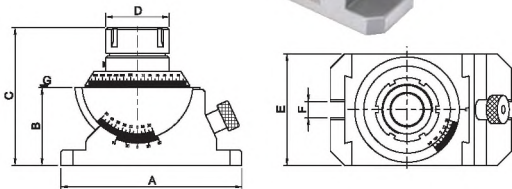

- Tolerance ±0.01mm/100mm.
- 360° horizontal swivel, 45° vertical tilting.
- Suit for multi - angle cutting.
- Simple way for mass production.
- Hardness : HRC52°±2°
- Load Capacity :25Kg



Standard Accessories: With 15pcs ER-40 Collet (4, 5, 6, 8, 10, 12, 13, 15, 16, 18, 20, 21, 22, 25, 26)

ORDER NO.	A	B	C	D	E	F	G.W (kgs)	CODE NO.
VUA-ER40	180	77	136	63	110	16	12	2003-065

Free Angle Rotary Chuck

NEW

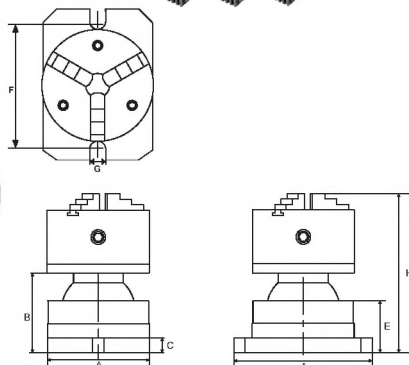

- With VSC-4, VSC-5, 3-JAW Chuck.
- O.D. Clamping ø3-90 mm (VSC-4)
- O.D. Clamping ø3-110 mm (VSC-5)
- I.D. Clamping ø 32-84 mm (VSC-4)
- I.D. Clamping ø 35-100 mm (VSC-5)

Features:

- Quick setting
- Operating is very quick and easy, can increase so much working efficiency than you can image.
- 360° Rotation, Tilting 30°
- For non-normal angle setting.
- Its swivelling and tilting features with chuck clamping make this unit for round & square, angular drilling machining on various machine tools or for bench work table.

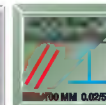

ORDER NO.	A	B	C	D	E	F	G	H	Weight (kgs)	CODE NO.
VAV-4J	140	120	20	190	72	158	17	203	16	1002-217
VAV-5J	140	120	20	190	72	158	17	203	17	1002-218