



# Hydraulic Machine Vise

HYDRO + MECHANICAL

PAT.

Power Build Out Type



# VERTEX®

HYDRAULIC MACHINE VISE



HYDRO FORCE INDICATOR  
A→H

COLLAR OPERATE

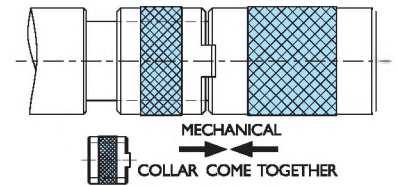

MECHANICAL  
COLLAR COME TOGETHER

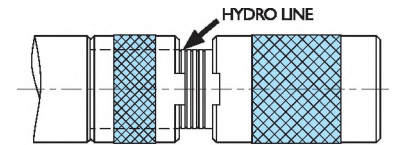

HYDRO LINE  
HYDRO  
COLLAR SEPRATE



MECHANICAL USEING  
SUIT FOR PROCESSING OF  
BRASS, AL, PLASTIC, STEEL,  
CASTING

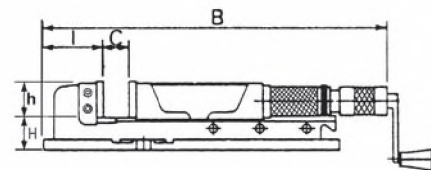
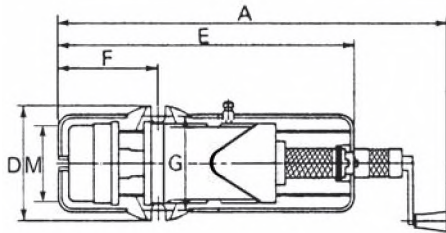

## Features

- Hydro : move the spindle until see the hydro line to work vise.
- Mechanical : move the spindle ring toward the end until the bushing close the hydro line.
- Heavy duty cutting.
- Hardness > HRC 45° : vise sliding bed.
- High durability & high precision.
- Tolerance : 0.01/100mm
- Lift proof : press down design.
- FCD 60 with 60 kgs/mm<sup>2</sup> or 80,000 psi high quality ductile cast iron - body material - reduce the cutting vibration.

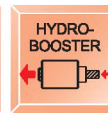

## VHO-VISE

ORDER NO.	A	B	C OPEN	D	E	F	G	H	I	M	h	Jaw w	Max. Clamp Force (kgf)	N.W. (kgs)	CODE NO.
VHO-5	695 920	545 775	0-220	190	505	180	160	74	105	130	55	130	3500	36.5	1002-220
VHO-6	750 1060	600 915	0-300	240	625	208	196	80	125	160	58	160	4000	59.1	1002-221
VHO-8	830 1140	700 1015	0-310	280	700	265	240	100	165	200	63	200	5000	94.3	1002-228

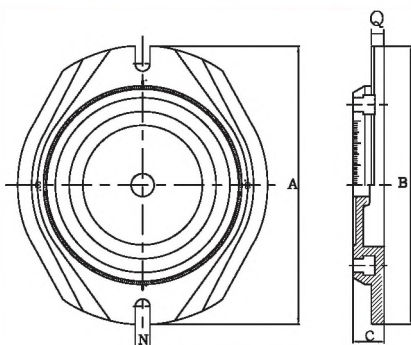

## Optional : Swivel Base

ORDER NO.	A	B	C	N	N.W. (kgs)	CODE NO.
HSO-5	285	263	35	16	12.5	1002-222
HSO-6	330	320	40	18	16.5	1002-223
HSO-8	415	413	50	21	35	1002-229