



Magnetic Tapper



NEW



※ knob may vary
& shape & color

Cost higher



Example.



- MAX. stroke 60 mm
- Suit for large workpiece
- TAP thread capacity M3-M12
- Magnetic force 80 kgf
- Horizontal / Vertical
- Portable
- Great for machine case & thin plate tapping job.
- TAP & Iron piece not included.

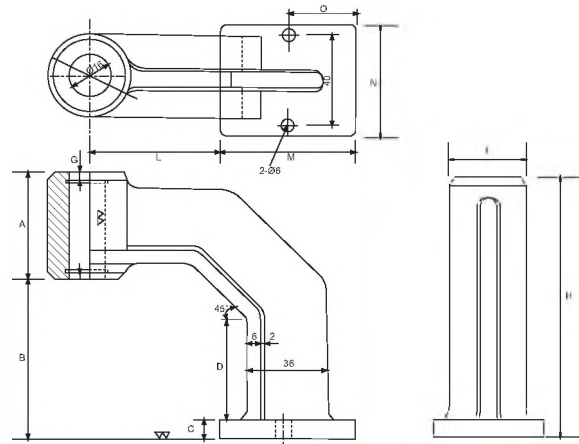

Unit : mm

ORDER NO.	A	B	C	D	H	I	L	M	N	O	WEIGHT (kgs)	CODE NO.
VTM-13	50	72	10	45	122	36	60	60	50	30	3.10	2015-731

MAGNETIC TAPPER