



Axial Drilling And Milling Heads



OFFSET

DIN 1809

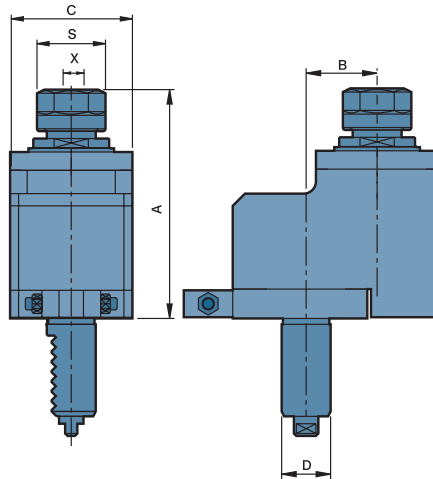

- Collet is not included
- To be used for collet DIN 6499
- External coolant supply

DIMENSIONS

i is speed ratio example:1:2. It's 2 times of speed

ORDER NO.	D DIN 69880	X Capacity	S	Maximum R.P.M.	i	A	B	C	CODE NO.
DA2018091629	20	1-10 ER16	30	4000	1 : 1	93.5	29	50	5006-030
DA3018092529	30	1-16 ER25	42	4000	1 : 1	100	29	60	5006-031
DA3018092529/1	※30	1-16 ER25	42	8000	1 : 2	100	29	60	5006-032
DA4018093250	40	2-20 ER32	50	4000	1 : 1	125.5	50	75	5006-033
DA5018094065	50	3-26 ER40	63	3000	1 : 1	124	65	86	5006-034



Radial Milling Heads

DISK CUTTER UNITS

※ ORDER MADE, NOT REFUNDABLE. DIN 1809

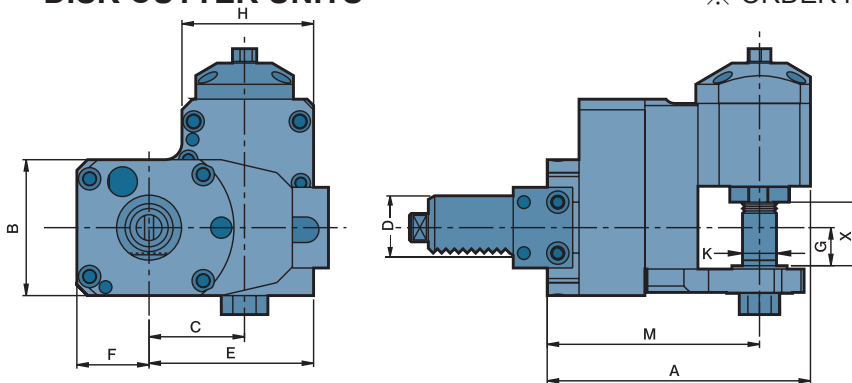

- External coolant supply

DIMENSIONS

i;(3:1),It's 3 times of speed decrease

ORDER NO.	D DIN 69880	X Capacity	Maximum R.P.M.	i	A	B	C	E	F	G	H	K	M	CODE NO.
BR30180916C/3 BL30180916C/3	30	16	3000	3 : 1	133	64	45	77.5	49	5	65	16	107.5	5006-035



Angular Heads

THE ANGLE IS ADJUSTED

DIN 1809

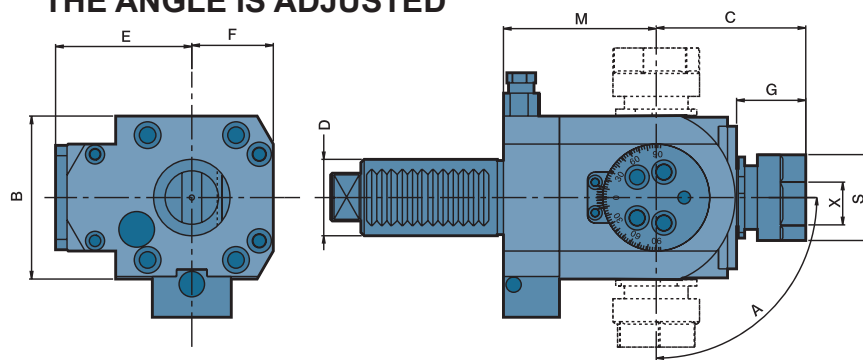

- To be used for collet DIN 6499
- External coolant supply
- Collet is not included

DIMENSIONS

ORDER NO.	D DIN 69880	X Capacity	S	Maximum R.P.M.	i	A	B	C	E	F	G	M	CODE NO.
DA30180920B	30	1-13 ER20	35	4000	1 : 1	±90°	64	59	54	32	27	60	5006-036A