

※All inserts are floating price.  
Contact us before ordering from F1~F49

EXAMPLE

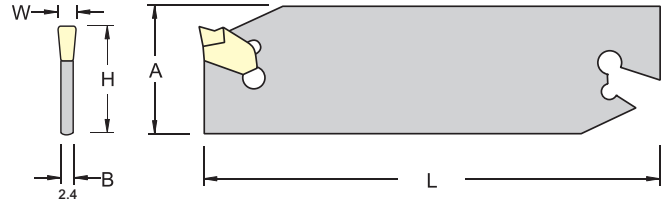
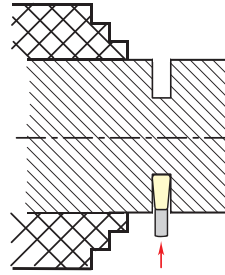

ORDER NO.	H	WORKING MAX. DIA.	W	B	L	A	INSERT	WEIGHT(kg)	CODE NO.
CGIH26-3	20	75	3	2.4	100	25.4	NGTN3	0.1	6004-030
CGIH32-3	25	100	3	2.4	150	31.3		0.2	6004-031

# Cutting Blocks



EXAMPLE



h1: FOR LATHE TOOL POST SIZE

H: IS CUTTING HOLDER HEIGHT FOR CGIH26-3 OR CGIH32-3

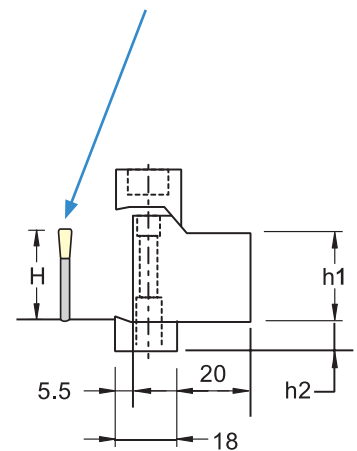
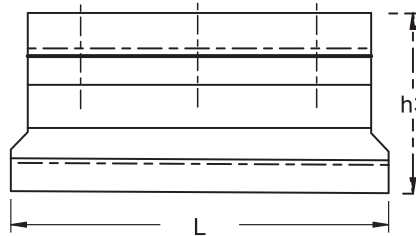
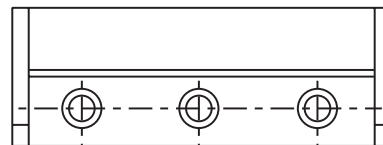

ORDER NO.	H	h1	h2	h3	L	Clamp	FIXING UNIT	Wrench	Cutting Holders	WEIGHT(kg)	CODE NO.
SBU20-26	20	20	10	45	80	BCS15	BX0622	LH050	CGIH26-3	0.8	6004-060
SBU20-32	20	20	13.5	50	100	BCS20			CGIH32-3	1.1	6004-061
SBU25-32	25	25	8.5	50	110	BCS25			CGIH32-3	1.2	6004-062