

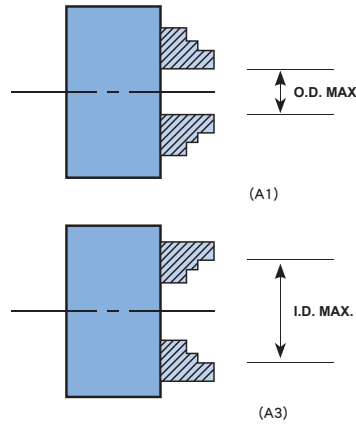

3-Jaw Powerful Scroll Chuck

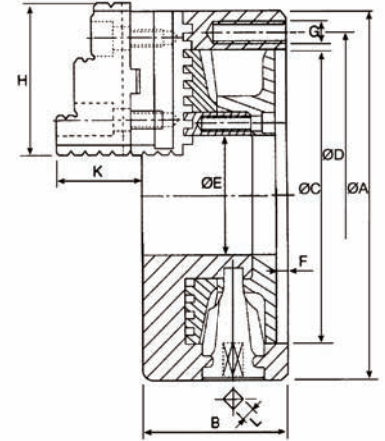

JIS STANDARD Accuracy Type

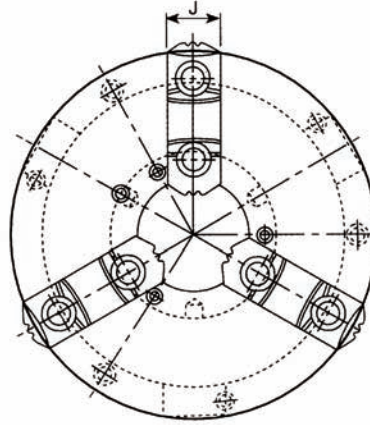

- VSK types chucks have wider utilization range; hard jaws suitable for heavy cutting; optional soft jaws suitable for light and precision cutting.
- Hard jaws could be used as internal jaws and external jaws.
- Gripping accuracy of 0.03mm(0.012inch) T.I.R.
- The body is made of MEEHANITE.
It is suitably used for high speed revolution and 3 times more durable than regular chucks.

SPECIFICATIONS

Unit:mm

ORDER NO.	Gripping Range	
	External Gripping ØA1	Internal Gripping ØA3
VSK-4	3-36	69-100
VSK-5	3-47	84-123
VSK-6	8-74	107-160
VSK-7	8-88	125-180
VSK-8	8-88	125-180
VSK-9	11-118	144-220
VSK-10	12-142	152-260
VSK-12	15-166	184-300
VSK-14	25-202	212-350
VSK-16	30-238	228-400
VSK-20	25-366	207-480

SPECIFICATIONS VSK reversible type

ORDER NO.	Dim											Allowable Handle Torque (kgf.m)	Gripping Force (kgf)	I (kgf.m)	Weight (kgs)	Max. Speed (r.p.m.)	Gripping Range		CODE NO.
	A	B	C	D	E	F	G	H	J	K	L						O.D. Range	I.D. Range	
VSK-4	112	58	80	95	24	4.5	3-M8	47	19	31.5	8	4.5	1200	-	3.45	2500	Ø3-Ø100	Ø35-Ø93	5002-028
VSK-5	132	60	100	115	32	4.5	3-M8	57	24	36	8	6.5	1500	-	5	2500	Ø3-Ø123	Ø43-Ø122	5002-029
VSK-6	165	67	130	147	45	5	3-M10	72	26	39	10	9.0	3300	0.03	9.5	2000	Ø8-Ø160	Ø55-Ø150	5002-030
VSK-7	192	76.5	155	172	58	5	3-M10	82	28	43	11	11.0	3600	0.06	12.8	2000	Ø8-Ø180	Ø62-Ø170	5002-031
VSK-8	200	76.5	160	176	58	5	3-M10	82	28	43	11	11.0	3600	0.07	14.7	2000	Ø8-Ø180	Ø62-Ø170	5002-032
VSK-9	232	84	190	210	70	5.5	3-M12	96	32	50	12	15.0	3900	0.16	20.4	2000	Ø11-Ø220	Ø70-Ø210	5002-033
VSK-10	273	87	230	250	87	5.5	3-M12	100	35	54.5	12	19.5	4800	0.26	26.7	1800	Ø12-Ø260	Ø80-Ø250	5002-034
VSK-12	310	96	260	285	105	7	3-M12	114	40	56	14	21.0	5700	0.58	39.3	1800	Ø15-Ø300	Ø90-Ø290	5002-035
VSK-14	355	112	300	328	127	7	6-M12	139	45	70.5	15	23.0	4500	-	60.7	1500	Ø25-Ø350	Ø110-Ø320	5002-035A
VSK-16	405	122	345	375	160	8	6-M14	150	50	75	15	23.0	4500	1.72	82.3	1500	Ø30-Ø400	Ø110-Ø380	5002-037
VSK-20	500	140	420	458	205	5.5	6M-14	140	55	84	19	-	-	-	145.5	1000	Ø25-Ø480	Ø125-Ø460	5002-038

SCROLL CHUCK