

Keyless Drill Chucks

TYPE:S

FOR DRILL ONLY , NOT FOR END MILL OR TAP



HEAVY DUTY TYPE S



Extremely high accuracy and precision design, suitable for CNC machines and machine center. All parts are ground, heat treated, surface treated and under specific QC condition.

ORDER NO.	Size	Capacity		Taper Mount No DIN or Jacobs	Length(m/m)		Outer Dia (m/m)	Weight (g)	CODE NO.
		mm	inch		Open	Closed			
12201-1	8S	0.5-8	0-5/16	JT1	68	76	38	460	3302-060
12201-2				JT2S	68	76	38	450	3302-061
12201-3				B10	68	76	38	420	3302-062
12201-4				B12	68	76	38	450	3302-063
12202-1	10S	1-10	0-3/8	JT2	80	92	43	660	3302-064
12202-2				JT33	80	92	43	630	3302-065
12202-3				B10	80	92	43	640	3302-066
12202-4				B12	80	92	43	670	3302-067
12203-1	13S	1-13	0-1/2	JT33	90	102	49	970	3302-068
12203-2				JT6	90	102	49	1020	3302-069
12203-3				B12	90	102	49	1040	3302-070
12203-4				B16	90	102	49	1030	3302-071
12205-1	16S	3-16	1/8-5/8	JT6	97	110	55	1330	3302-073
12205-2				JT3	97	110	55	1330	3302-074
12205-3				B16	97	110	55	1340	3302-075
12205-4				B18	97	110	55	1360	3302-076

KEYLESS DRILL CHUCK

Keys Steel

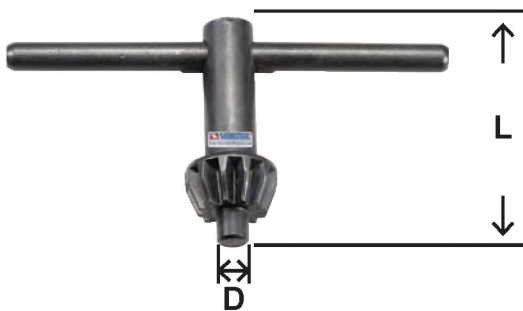

ORDER NO.	Type	Dmm	Lmm	Weight(g)	Packing	CODE NO.
14001	T1	3.2	35	20	Plastic Bag	3304-100
14002	T2	4	42	40		3304-101
14003	T3	5.5	44	45		3304-102
14004	T4	6	45	55		3304-103
14005	T5	6.5	45	50		3304-104
14007	T7	8	50	80		3304-106
14008	T8	9.5	65	150		3304-107
14009	T9	11	100	320		3304-108

Note

CAUTIONS

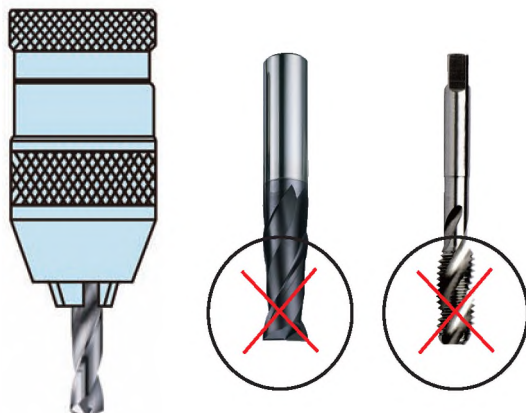

- CAUTIONS:
- ※ DO NOT USE END MILL AND TAP WITH DRILL CHUCK
 - DRILL CHUCK ONLY CAN PROCESS VERTICAL JOB.
 - ADD COOLANT WHILE HEAVY CUTTING.
 - ※ WHILE PROCESSING:
 - DO NOT MAKE HORIZONTAL MOVEMENT OR ELSE, IT WILL CAUSE 3 JAWS' DEFORMATION.
 - NOT FOR END MILL.