



Heavy Duty Tilting Plate



TILTING PLATE & CLAMPING HANDLE

NEW

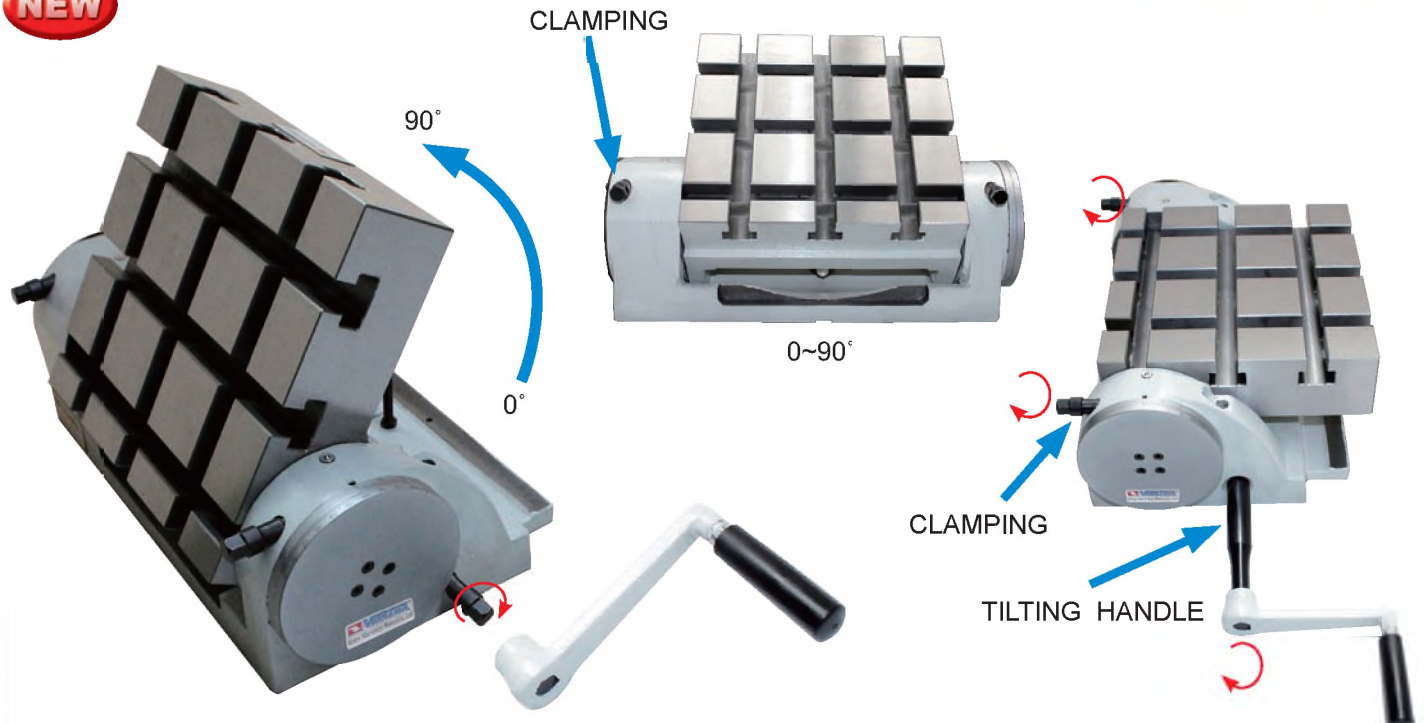

ORDER NO.	Horizontal	Vertical	CODE NO.
VUT-1515	30 kgs	12 kgs	1004-110
VUT-2726	45 kgs	20 kgs	1004-111
VUT-3230	70 kgs	35 kgs	1004-112



USING EXAMPLE:

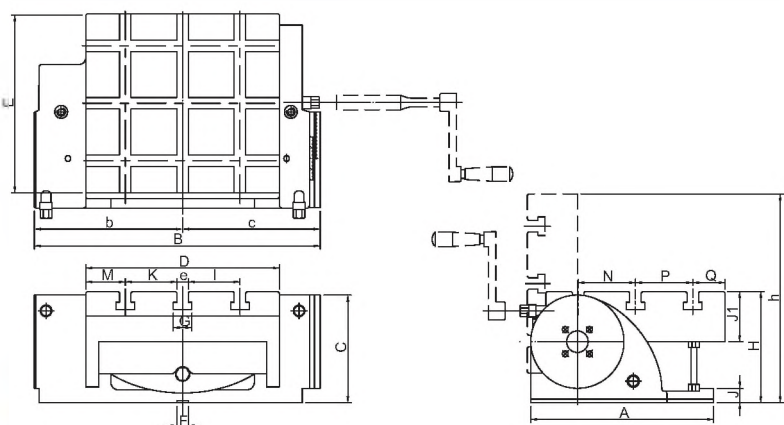
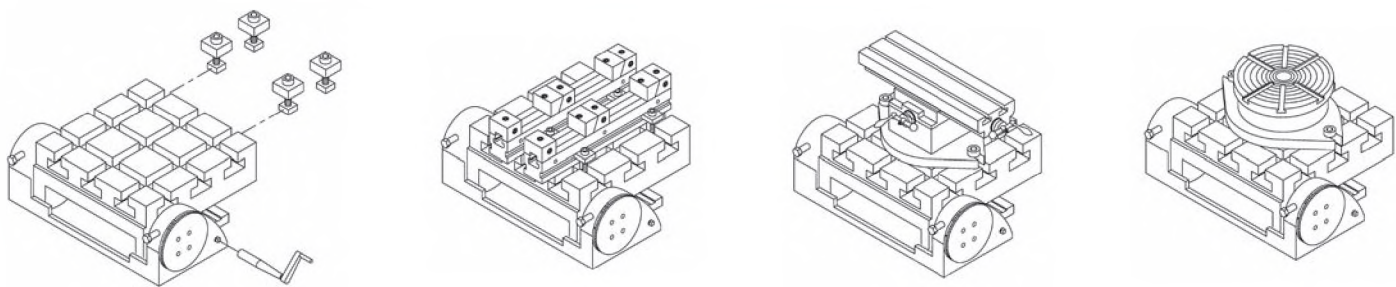

- Tilting by rigid & strong design, 2 supporter & rigid clamping system construction.
- Minimum set-up time.
- Tilting angle can adjusted by worm & worm gear system.
- Accurate and built for use in milling, boring and other machines.
- Worm shafts are hardened and ground.
- Tilting plate with slots enable Multi-position work fixing.
- Strong structure.
- FC 25

Unit:mm

ORDER NO.	A	B	C	D	E	F	G	H	I	J	J1	K	M	N	P	Q	b	c	e	h	KGS	CODE NO.
VUT-1515	180	285	113	156	150	16	20	115	44	16	50	44	28	50	50	30	145	140	10	251	17.6	1004-110
VUT-2726	255	399	150	270	258	16	22	155	72	20	70	72	55	80	80	45	207	192	12	291	59.4	1004-111
VUT-3230	300	449	169	320	298	16	26	169	92	25	75	92	60	98	100	48	232	217	16	305	83	1004-112